

INTRODUCTION:

Anyone might enter places, where we may feel chest tightness or discomfort, and sometimes one can enter places where one gets to feel very comfortable. One sometimes meets people to whom one feels attracted, while other times among other people whom one is not compatible with, and cannot accept. So, each place has its own resonance, its ethereal vibes, or its positive energy that makes us feel comfortable. Some places have strong negative energies that repulse us and make us unable to stay longer in them. The same thing applies to people; each person has his energy, or what is called the spectrum, or aura that surrounds him.

Therefore, for us, energetics is like metaphysical sciences, and it is considered a world that lacks the earthy physical form. It only depends on the form of energy that does not occupy a space. Hence, one does not see it, but one feels it, it has effects on us, our feelings, and emotions.

The artworks (drawn or colored) that exist in a place may contribute to creating a new mood that improves the place's energy and vibes.

RESEARCH PROBLEM:

Does the art of drawing affect improving the recipient's mood? And does Bio-energy transmit this effect?

RESEARCH AIM(S):

This research aims at highlighting the value of the drawing art and its impact on the recipient through bio-energy sciences.

RESEARCH IMPORTANCE:

The creation of a new area and space between the art of drawing and the recipient in terms of affecting and being affected by the conscience, the feelings, the emotions, and the moods caused by positive energies transmitted to the recipient through the painting.

RESEARCH HYPOTHESES:

- The research assumes that through the techniques of the art of drawing from lines and areas of color, several bio-energies that spread in the environment and affect the recipient negatively or positively.
- The research assumes that bio-energies emitted from drawn artworks have their effective role in the emotional states and moods of the recipient.

RESEARCH METHODOLOGY:

The research follows the analytical approach.

SPATIAL & TEMPORAL BOUNDARIES:

In Egypt during the twenty-first century.

POTENTIAL ENERGY:

According to its scientific definition, energy is the ability to affect at any time. There is potential energy, but when it interacts, one sees its impact as indicated in illustration no. (1),

where the energy is gathered in the center of the shape or mass. For example, "one does not see the energy of air but, one perceives its impact on the movement of things." Since man is the center of life, the science of "Bio-geometry" focuses on him, this is what Dr. Ibrahim Karim calls qualitative physics since chemical physics has a crucial impact, but only in the laboratory, while bio-geometry, on the other hand, has also an impact on humans. This impact area is where bio-geometry intervenes.

“Bio-Geometry is the patented science of using the energy principles of shape to qualitatively balance biological energy systems and harmonize their interactions with the environment. Balancing the activities of daily life, achieving harmony with our inner and outer environments, humanizing modern technology, and integrating science and spirituality is the work of the science of Bio-Geometry. ”

— Dr. Ibrahim Karim said "Bio-Geometry is the practical application of an innovative science developed by Dr. Ibrahim Karim, an Egyptian Architect, and Research Scientist. Bio-Geometry seeks to positively influence the energy of physical environments and living systems through the Energy of Shape, revitalizing an ancient awareness of the impact of geometrical shapes on human energy systems.

Through the application of Bio-Geometry, we can tap into the subtle invisible energy fields around us to help us find balance in our daily lives and between our inner and outer environments. The very practical use of Bio-Geometry is to humanize modern technology and its pervasive and harmful electromagnetic waves. By using specially designed shapes and design principles, a superior beneficial energy quality can transform the energy of any environment or living system". (<https://www.hollysteflik.com/biogeometry>)

THE PSYCHOLOGY OF LINES AND THEIR IMPACT ON THE RECIPIENT:

“Bio-geometry” is included in every element of life since it is a holistic science, i.e., its applications are endless in our world, regardless of our specialties or interests. It is the language of forms and colors and how they affect the areas around us in the sea of energy in which one lives (and which one does not perceive with our limited senses)” Abdul Fattah Riyadh. (1995) (P.112, paraphrase).

By designing whether, for buildings, furniture, or paintings of lines and color areas, balance can be introduced in favor of Man. Applications of science are concerned with the impact of environmental pollutants on human health to protect him from terrestrial, electromagnetic radiation, and all radiation resulting from modern technology usage.

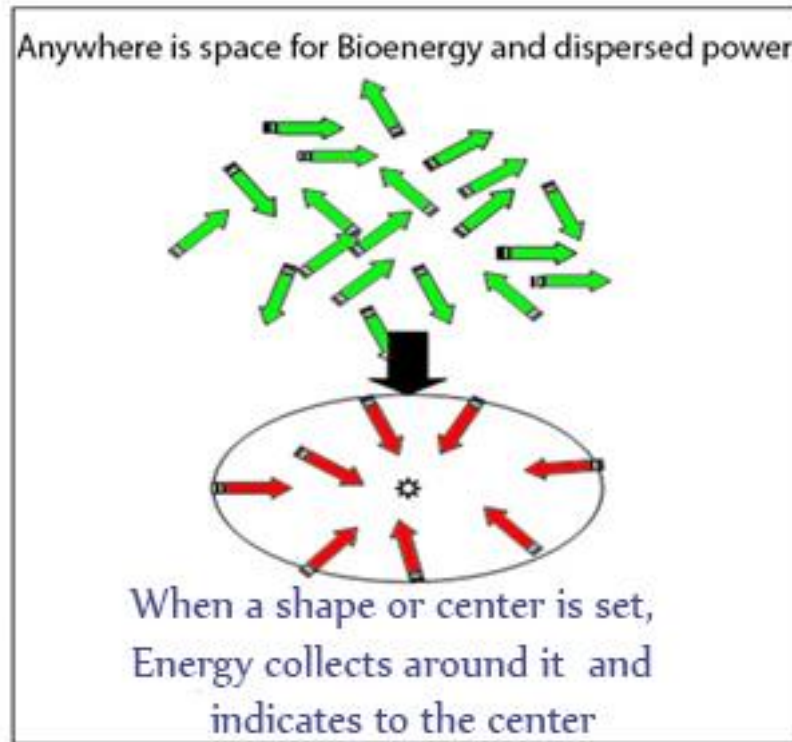

Figure No. - (1) (Illustration to bioenergy atoms in a vacuum and others clustered around a figure)
(Lobna Abd Elaziz)(2006)

There are potential kinetic forces, running in this direction, and they gather at the ends of any line, whether it is straight, curved, or wavy. The line is tied to a movement, and its movement will only be a result of the energy that, when begins, it tends to continue. The beholder of the short straight line tends to imagine that it has extended on one or both of his sides, until it becomes a long straight line, as in figure no. (2). The beholder of the curved line tends to imagine that this line has extended its curves, as he tends to imagine this wavy line with an increase of its wavy units. This kinetic energy inherent in the lines makes it easy for the individual to perceive the sets of interrupted lines as a continuous unit" Abdul Fattah Riyadh. (1995)(P. 114,116,125 paraphrase).

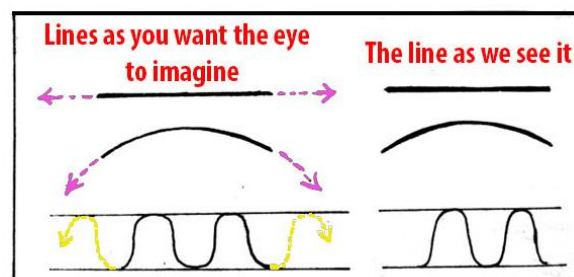

Figure No. (2)(Illustration to the visual extension of lines and the direction of their energy)
(Abdul Fattah Riyadh) (1995)

Given the fact that every line has an energy that heads in the direction of the line, it is undoubted then that if the drawing composition includes many opposing lines, then these energies must interact or conflict, as each of them directs its energy in a direction, different from the other. "The matter that evokes intense kinetic sensations and these kinetic sensations

increase in case the Recruit of drawing composition represents groups of lines, each of them or some of them are characterized by a rhythm different from the other. The laws of motion state that every action has an equal and opposite reaction. Perhaps it is easy to apply this law, in the field of visual perception, since there is kinetic energy that has been directed in a specific direction and it must have a kinetic reaction as well.” Abdul Fattah Riyadh. (1995)(P. 131,133 paraphrase). Likewise, one can imagine the lines of the artwork when one sees them on the surface capable of emitting various energies that evoke a conflict” resulting from their clumping together on one surfacing.

TYPES OF DRAWN LINES:

The drawn line expresses the personal and mood energy of the artist, which is actually transmitted to the recipient.

A. - STRAIGHT, HORIZONTAL LINES: Straight, horizontal lines act as a floor or a base; suggest persistence, calm, and stability especially, if they are found at the bottom of the picture. Horizontal lines are connected in our imagination to the earth, which is the most stable and persistent creature. They also suggest comfort since they are subconsciously tied to the shape of the human body while relaxing or asleep. The horizontal parallel lines differing in thickness, length, and position evoke rhythms that depend on the extent of convergence or divergence of the groups of these lines, the one may see it as visual music.

Vice versa, if the horizontal lines of similar length, thickness and space increase, they evoke a sense of dull monotony. Therefore, one considers that the existence of both vertical and horizontal lines make a balance with the dynamic forces that flow in the horizontal direction. As for the slightly diagonal and relatively short lines, they may play a vital role in the dynamic excitement of the horizontal compositions, so one can see a dynamic excitement in the shape that guides the eye to the sovereignty center in it.

B. - VERTICAL LINES: Also they symbolize strength and a sense of vertical growth, such as the growth of plants, buildings, and facilities, as well as dignity, greatness and solemnity. One considers that both vertical and horizontal lines make a balance between forces with opposing directions, the vertical line, expressing the Earth's gravity and the horizontal line, expressing stability and surfacing, one finds that they play together a role in exciting balance sensations in forces. Therefore, it is desirable to support the vertical lines with other horizontal lines intersecting with them. When the frequency and crowding out of vertical longitudinal lines increase, the sense of strength and toughness increases, and when the frequency of horizontal latitudinal lines increases, the sense of comfort and stability increases.

C. - CURVED LINES: They suggest gentleness, agility, tenderness, femininity, and softness. If the curves increase and the rotations increase significantly in mass, areas, or corners with the erasure of all squares and sharp shapes, then the shape does not express the previous meanings, rather it may express weakness, dissolution, and relaxation. Some tests were conducted on paintings, excluding color, masses, and known shapes, in order not to be subjected to the whims and preferences of people. It was a set of only soft and curved lines. The result was that most people agreed that paintings with wide curves suggest calm and that

the small angles and the many narrow curves suggest disorder and confusion. Many people think of paradise as a huge canopy that brings together the poor and the rich, the man and the woman, and the old, the adolescent and the child, etc. Hence, one considers that the human approval of the curve canopies design in facilities of a social nature, such as mosques, churches, and conference rooms. The repetitive curves of wavy nature evoke sensations of periodic movements such as breathing and throbbing of the heart. Thus, they express the rhythm of dynamics.

D. - DIAGONAL LINES: They may evoke sensations of movement, upward or downward, as they deviate from the stable vertical and horizontal positions. Therefore, the diagonal line is filled with energy that emits in the vertical and horizontal directions as shown by arrows in figure no. (3). It gives sensations of instability or imbalance. Therefore, diagonal lines require to align with lines corresponding at the inclination to balance. Perhaps what the diagonal line or body evokes of sensations of fall is the direct cause of its subconscious link to the movement. The fall is movement; therefore, the diagonal lines are tied to the sensations of movement...



Figure No. (3) (Illustration to the direction of the diagonal energies) (Abdul Fattah Riyadh) (1995)

Since painting is an art that depends mainly on the line in its production, it affects the recipient by the psychology of lines through the bioenergy perceived from the lines of artwork. Whether those lines increase or decrease, whether they are vertical, horizontal, or diagonal, whether they are straight or curved, they have an effect on the recipient, in terms of their movement, their directions, and the energy perceived from them and thus its effect on the place. Since every action has a reaction, the act of drawing lines, the resulting directed movement, and the energy perceived by the artist and directed to the surface, have a definite reaction of the recipient, being influenced by the movement of the lines and their energy. Thus, bio-energy affects the place, whether negatively or positively, and it can be used as a type of energy therapy, and to create a qualitative balance in the perimeter and the space of the place to improve or harm the bio-energy that affects humans.

THE BIO-ENERGY OF THE ANCIENT EGYPTIANS:

The ancient Egyptians possessed a broad knowledge of Bio-energy, and its use had a great impact on civilization. They produced shapes and symbols that have a spiritual character and have their harmony on the earth and their effect on the human body. It has relied on some inscriptions as a form of the "life key" as one of the tools for transmitting Bio-energy, figure No. (4), figure no. (5) represents the concept of "the ka", which is one of the most important parts of the human body for the pharaohs, which is the spirit that is born with man, and give him life force, and to return to the body after death, life energy must be derived from the outside world, which is known as Bio-energy. (Motaz, Mohamad, (2019) p. 81) (Paraphrase). This reminds us of the most important source of energy in the human body, which is the purple luminous energy as in figure No. (16) in our modern world.

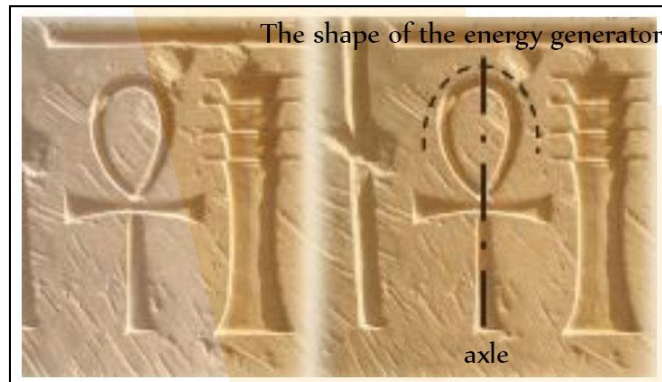

Figure No. (4)(Illustration of Movement of energy emanation from the symbol of the life key of the ancient Egyptians) (Motaz,Mohamad,(2019) p. 81)

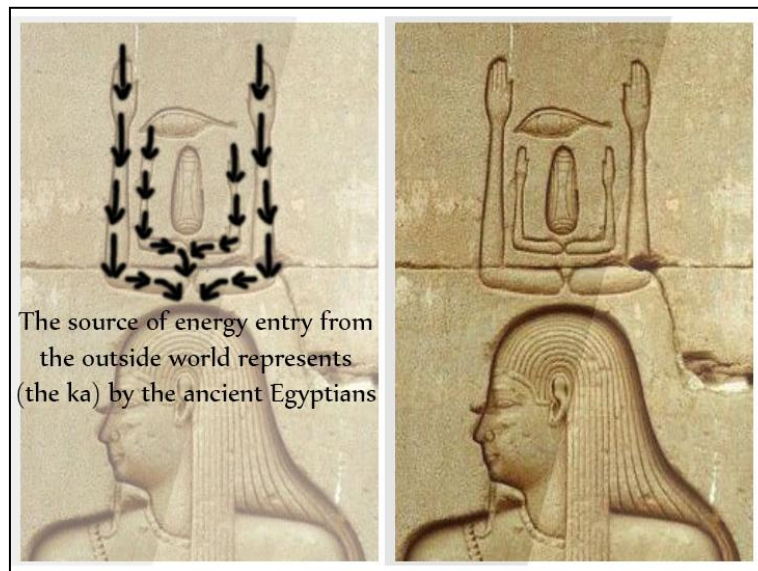

Figure No. (5) (Illustration to entry of energy from the outside world into the human body through (the ka) symbol of the ancient Egyptians) (the researcher).

THE PSYCHOLOGY OF COMPOSITION:

“Man realized the reality of the psychology of composition since ancient times, therefore he started to study the creatures of God on earth and aspired relief and knowledge from them.

Things that man devised from nature is the "Golden Ratio" figure no. (6). It is a unique

number and is mysteriously related to the origin of life, and its value is equal to 1.618. By studying many plants and vital organs, it is found that the golden ratio unreasonably applies to them, as Pythagoras discovered the golden ratio on the basis that it is the relationship that governs the universe and achieves its unity. Furthermore, Pythagoras argued that everything stems from numbers, and that digital relationships reflect the harmonic structure of the universe” Lubna Abdel Aziz (2006) (P. 41 paraphrase).

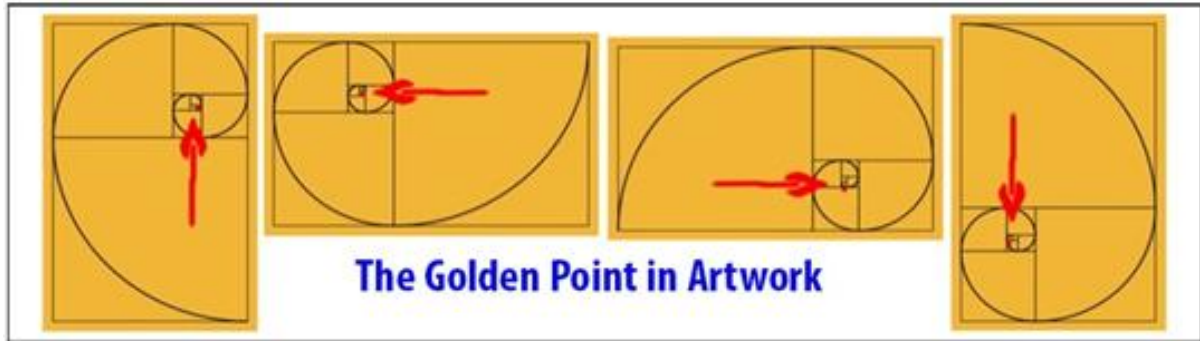

Figure No. (6) (Illustration to the Golden Ratio within a piece of art)

<http://movryors.blogspot.com/2013/08/blog-post.html>

The golden ratio has been criticized by those who have a materialistic view, as they stated that beauty does not lie in the visible thing itself, but is created through the interaction between the visible and the recipient. Therefore, one argues that the relationship that is created between the visible and the recipient is the result of the resonance between them, which was caused by following these ratios that coincided with the ratios of what lies inside the recipient or the nature surrounding him, figure no. (7).

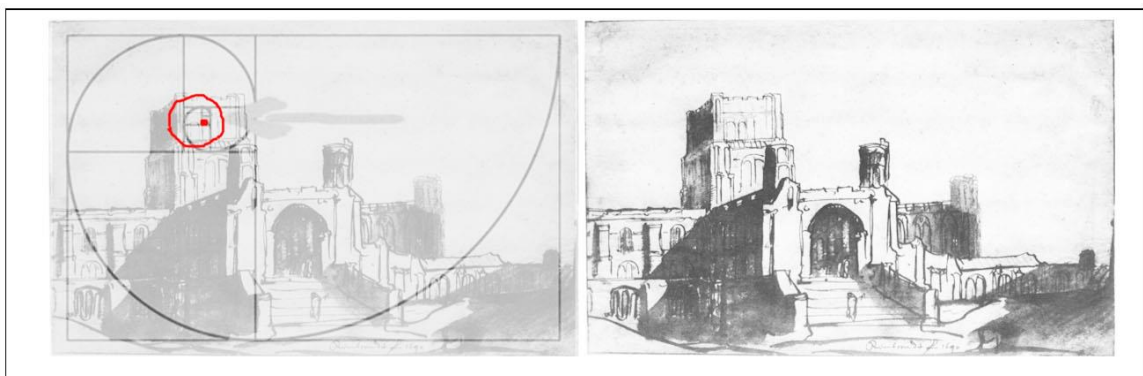

Figure No. (7) (Rembrandt - St. Albans Cathedral - Drawing ink – 1640) (the researcher)

(1606- 1669) was a Dutch draughtsman, painter, and printmaker, an innovative and prolific master, generally he is considered as one of the greatest visual artists in the history of art and the most important one in the history of Dutch art) (<https://en.wikipedia.org/wiki/Rembrandt>)

Rembrandt achieved the golden ratio, where the eye automatically turns to the castle located in the upper left of the work and then turns to the rest of the parts and elements of the work.

This is what the modern scientific view adopts, as modern sciences in all fields have shown that our world is governed by universal laws that operate at all levels, whether perceptive or not. To understand all our surroundings and reach a unified dialogue with our environment,

one must realize that man, animals, inanimate objects and all beings are nothing but energy in one form or another, and everybody has a ray of energy or vibrations emanating from the laws governing it, that can be deduced from the outward appearance. These laws are the language of dialogue between it and those around. Harmony may occur among them and also dissonance may occur, producing a mutual negative effect. Everyone participates in the energy field surrounding us, each according to its type and intensity of energy or its field, thus, one finds that the composition is one of the most important reasons for the success of the artwork. In an attempt to identify the most successful art formations, after many experiences and expertise in several forms, scientists concluded that the best forms of formation within the framework of the artwork are the hierarchical form (A), the circular shape (O), and the shape of Letter (L), meaning that the elements of composition in the artwork and its vocabulary should take these shapes around the surface of the painting.

A. - HIERARCHICAL CONFIGURATION:

Hierarchical formations within the artwork form a feeling of firmness and dramatic power that cannot be giving by any other composition, so the geometry of the hierarchical shape through the ratio, dimensions, and axes of its orientation works to completely modify the electromagnetic properties inside the pyramid. Also, the use of these ratios and their repetition in a specific pattern between them brings about resonance, that is a repetition of the cosmic ratios and then of the entire universe, these frequencies are so weak that they cannot be observed or recorded except through their effect.

The three pyramids continue to be the world's greatest wonder. Their miraculous building with such superior knowledge and know-how makes the world stand perplexed, wondering about the greatness and knowledge of the ancient Egyptians, and with each new era, scientists discover new secrets carried by these pyramids and their shape. Engineering scientists say that the pyramid shape has an unnatural ability to attract the geomagnetic field in huge quantities with all the amazing energies it contains. Experiments have shown that the milk remains fresh inside the pyramid for several days without deteriorating, the jewelry and coins return to their old luster, the minerals become harder and stiffer, and the plants inside it grow faster, also wounds, blisters, and burns heal faster inside the pyramid than outside of it. Thus, when artists use the form of hierarchical composition, they unintentionally create bio-energies that emanate from their work, and affect the recipient and the place in a "positive and tangible" way, as shown in figure no. (8).

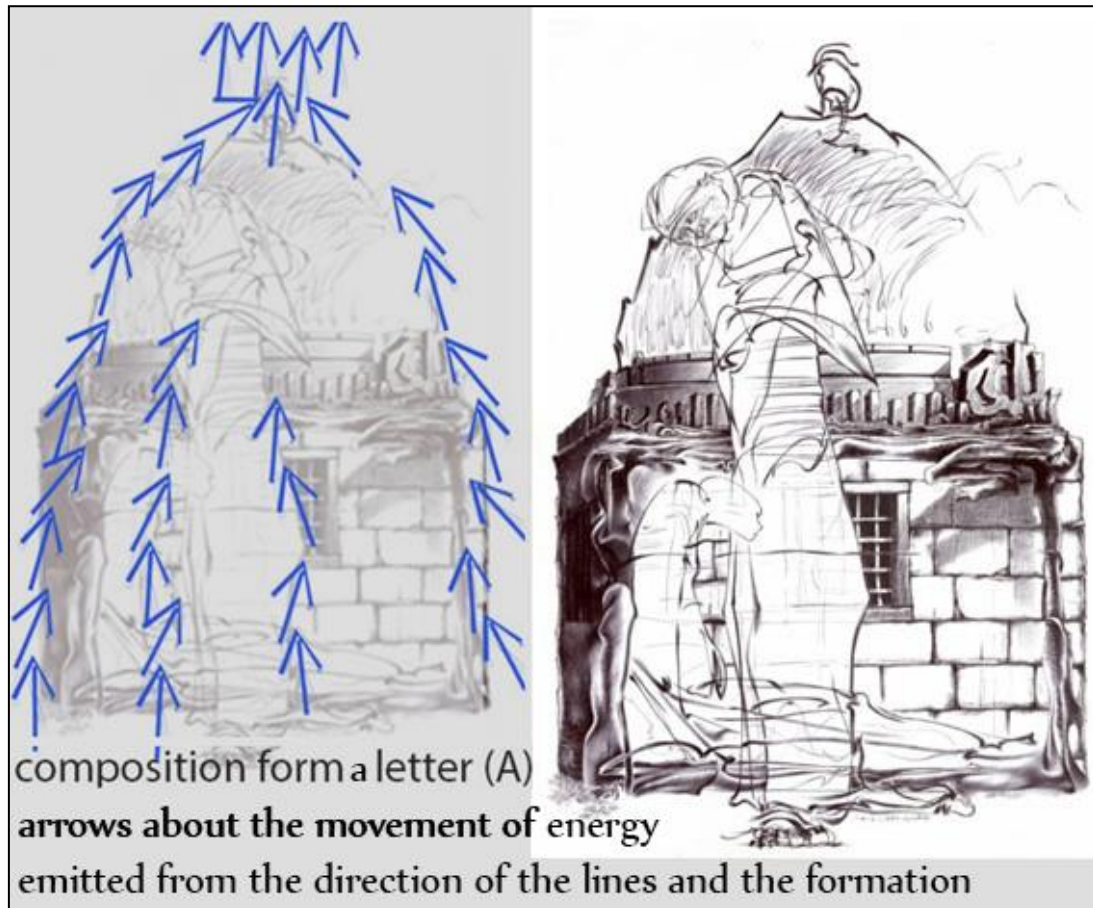

Figure No (8). (Badr El Din Awad - from the " Grave Visitors" Group - 31 x 45,5 cm - pen drawing – 2004) (the researcher). An Egyptian artist and engraver, born in Domiat, 1963, a Graphic Professor, at Faculty of Fine Arts, Helwan University)

Artwork by the artist "Badr Al-Din Awad", and figure no. (9) is an artwork by "the researcher" where they used in the composition of their artworks the hierarchical shape that suggests strength and firmness, which carries organized and balanced energy. they also used the technique of pens with its strong curved lines carrying a flow in the movement that emits dynamic energies in human beings at work, as for the other lines- They are straight in the dome and the walls, creating a linear optical balance that reaches to the receiver as regular energy carried by those vibrations in the space between the receiver and the artwork. The left illustration expresses the movement of the energy direction emitted from the drawn lines of the artwork and the hierarchical formation as a letter(A). The artistic analysis of the lines in this artwork shows that the direction of the lines goes upward, where all the lines meet in one focal point, where the potential energy of the drawn lines lies, continuing their direction upward. This energy is transmitted to the recipient, the moment he/she casts a look at the drawn artworks, that take their shapes from the pyramid, and stimulate some sort of unconscious imitation in the recipient, thus the negative energies get out of the recipient's body, in a similar technique and heading in its direction from downwards to upwards, where the receiver's head is, in a focal point, at the top, and spreads in the space, in the same manner, the pyramid-shaped artwork lines go upward.

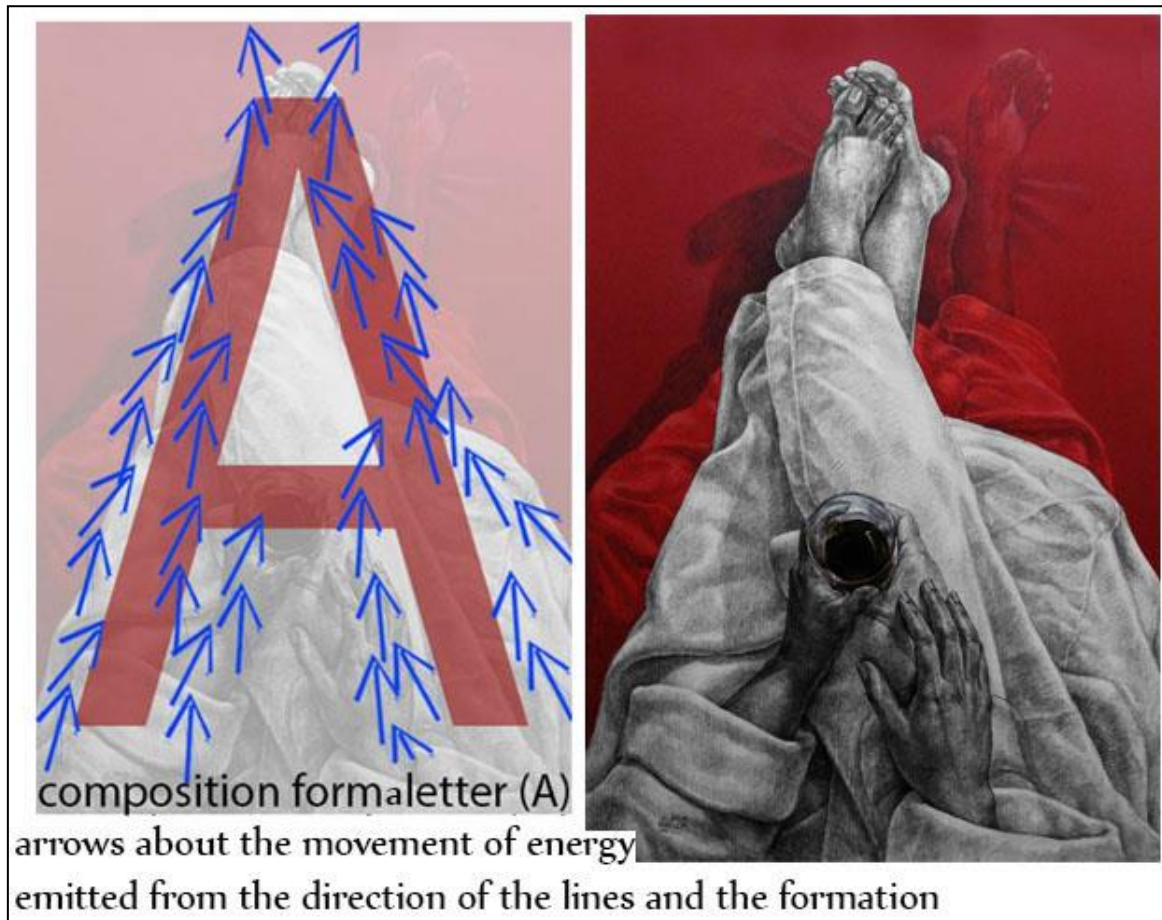

Figure No(9). (the researcher – relaxed- 170 x 110 cm – a drawing by pencil & Acrylic on canvas– 2012)
(the researcher)

B. - CIRCULAR CONFIGURATION:

"A circle is a series of curves of a wavy nature that one sees in decorative works that indicate human approval for this style of lines, and a circle is a set of connected curves that have no beginning or end and do not indicate a specific direction, so it creates a case of equivalence (Abdel Fattah Riad 1995 P. 134 paraphrase). Especially the spiritual function that the circular shape carries in the world of spirituality, it provokes a sense of movement as one finds in "**Feng shui sciences**" (It is an embryonic form of environmental science, affecting urbanization and construction. The first pioneers of this art in ancient China were known as doctors who healed their patients with bio-energy." (<https://www.ahewar.org/debat/show.art.asp?aid=125039> (1-9 - 2020).

When they use the decorations, whether internal or external, they move away from "**hidden arrows**" or "**Poison arrows**" (are invisible lines of the bio-energy of the place emanating from the corners of objects, manufactured from architectural forms and furniture") (Ibrahim Abdullah Aba `al-Hora, 2017) and tend to rotate things, whether in furniture or buildings, and they deviate from anything that is sharp or creates many angles in the place, so as not to impact the language of bio-energy on the person and transmit to him/her hidden arrows that usually come out from a sharp and constant angle, and the frequent repetition of such arrows emerging from the manufactures and furniture will accumulate in the human body, leaving negative inner energy, causing harm, and therefore anyone will notice that in places of

worship (e.g. mosques and churches) there is always an abundance of round domes, whether in the ceilings or in the walls, in order to give a sense of comfort, tranquility, and calm. Each system has a center that wraps around an elemental circle, and each element also has its center, such as the universe and galaxy system, which takes a circular shape. Consequently, this rotational motion results in regulated re-energized energy, (Motaz, Mohamad,(2019) p. 84) (Paraphrase). The greatest example of the energy of the circular shape is the movement of worshipers rotating around the Kaaba, which produces high spiritual energy, and the circle expands to include the whole world when all the mosques of the world are directed towards one direction (the Kaaba) that strengthens the spiritual energy that creates a circular shape around the world with the center of (the Kaaba) as in figure No.(10)

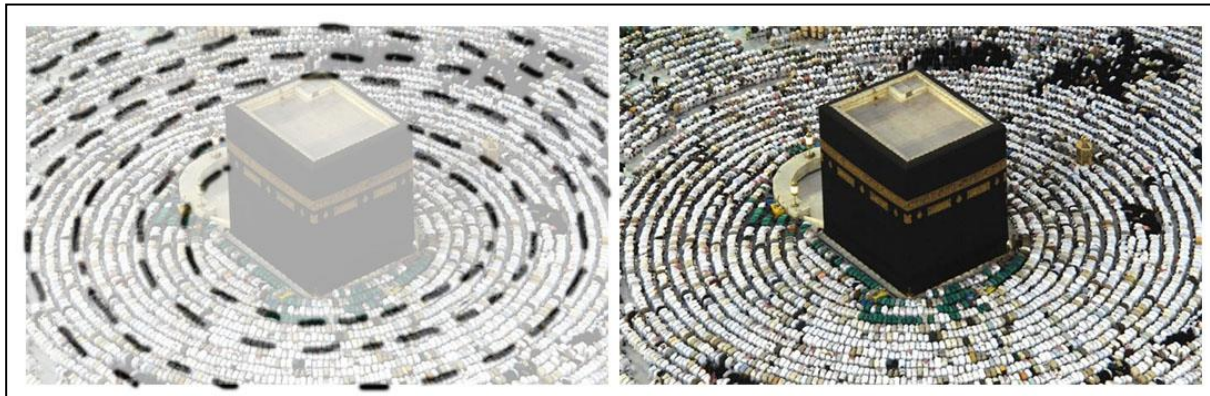

Figure No(10). (An illustration of the circular energy movement of the worshipers around the Kaaba and its high spiritual state) (the researcher).

Christian civilization has known the energy that enters the body as rays, and the one which comes out of it is called aura. Concepts of energy have appeared through icons that depict the dashing aura by surrounding the heads of saints with colors that express the luminous and spiritual energy that works to spread the positive energy of the devotees.(Motaz, Mohamad,(2019) p. 83) (Paraphrase).

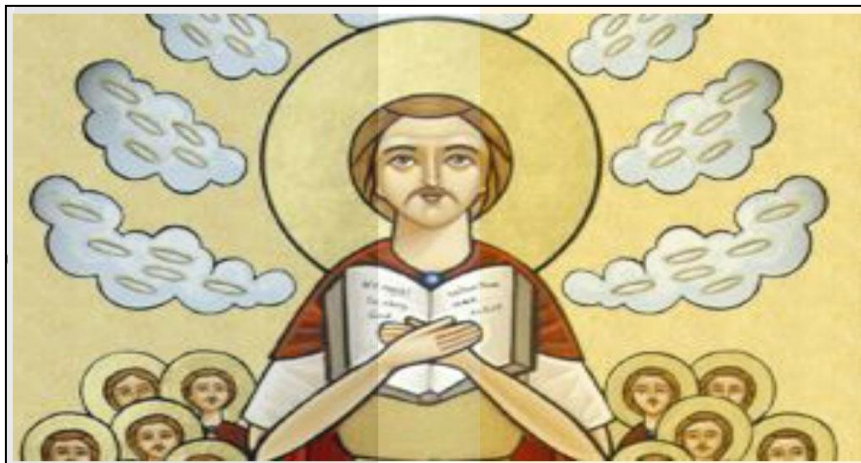

Figure No(11). (Illustrative image of the luminous aura of the saints) (Motaz,Mohamad,(2019) p. 83)

In figure (12), the artist "Awad El Shimi" used the circular shape in many of his works as the frame form that combines all the elements of his formations, which added a spiritual and contemplative dimension to his works of the circular shape, in the language of the science of

energy, the artist generated and emanated a state of rest and stillness from the circular shape in his work.

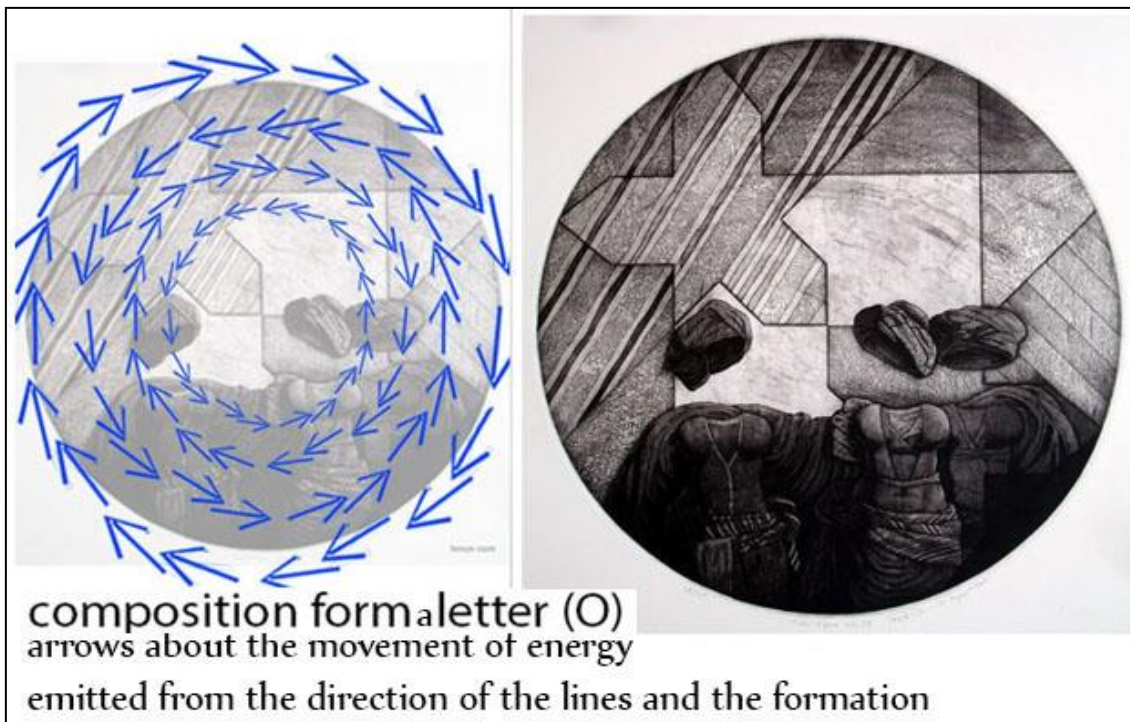

Figure No. (12)(Awad El-Shimi - from "El-Jariya" Group - a printmaking - engraving etching – 1992) (the researcher) (An Egyptian artist, born in Cairo in 1949, a distinguished engraver with a clear imprint in the field of graphics. Professor of Graphic at Faculty of Fine Arts, Helwan University).

The artist also used the technique of engraving etching, which partly depended on the effect of aquatint and the effects of acids, and the other part depended on short lines that are parallel at times and intersecting at other times, to carry the movement and create varied energies emanating from his smooth, calm lines transmitted to the receiver through vibrations that interpret the energy emitted from such lines, shapes and vocabulary of the artwork, so that it has a positive effect and he works on the qualitative balance of the bio-energy due to the harmony and movement of the soft and quiet lines, and the formation of the spiritual magic ring, the form that gives calm and tranquility to the recipient. The artistic analysis of the lines in this artwork shows that, when looking at it, a group of energies, represented in the curved lines of the circular curved lines. The curved lines appear to be as if they are in a state of endless, non-stop, and continuous circular movement, such movement gives the recipient an impression of having the same circular movement within himself/herself, thus transmitting a feeling of stability, stillness, and tranquility, suggested by the circular shape, or the energy of the curved lines. This energy, which puts the receiver in a state of stillness, containment, and probing of the depth of his/her inner self, where his/her thinking becomes deeper and more focused. Despite the different energies emitted from the other lines, presented in the interior design of the artwork, since the artist employs the technique of deep acid "engraving etching", in which he depends in one part on the effect of watercolors and acids and in the other part on short lines that sometimes align with each other and at other times they intersect together. These short lines carry kinetic energy and other various rich energies that emanate from his calm and soft lines. The energies emitted from the lines, the shapes, and the elements of the

artwork are transmitted to the recipient, giving him/her positive vibes and affecting him/her positively, striking a bio-energy qualitative balance, as a result of the artwork's harmony, the calm and soft movements of its lines, and its spiritual and magical circular shaped structure, that adds serenity and tranquility to the recipient. The left illustration of the artwork expresses the movement of the energy direction emitted from the drawn lines of the artwork and the Circular shape as the letter(O).

C.- THE FORM OF THE LETTER (L): "Shapes, in general, emit certain energy fields around the human body, and Dr. Ibrahim Karim says that when a certain geometric drawn shape appears on electronic devices, such as a mobile phone, a television, or any other device, or even near the device, this shape affects the person and makes him/her stronger, and though this does not eliminate the device's damages, it alleviates the harmful impact of the device on the user, and this shape resembles the letter "L". Dr. Ibrahim Karim has released "(L66) Figure No.(13) emits strong levels of BG3 converting detrimental energies, such as EMFs, into beneficial energies, which can be used on windows and mirrors if the objective is protection from external electromagnetic influences". (<https://www.pinterest.com/pin/329466528988861999/>)

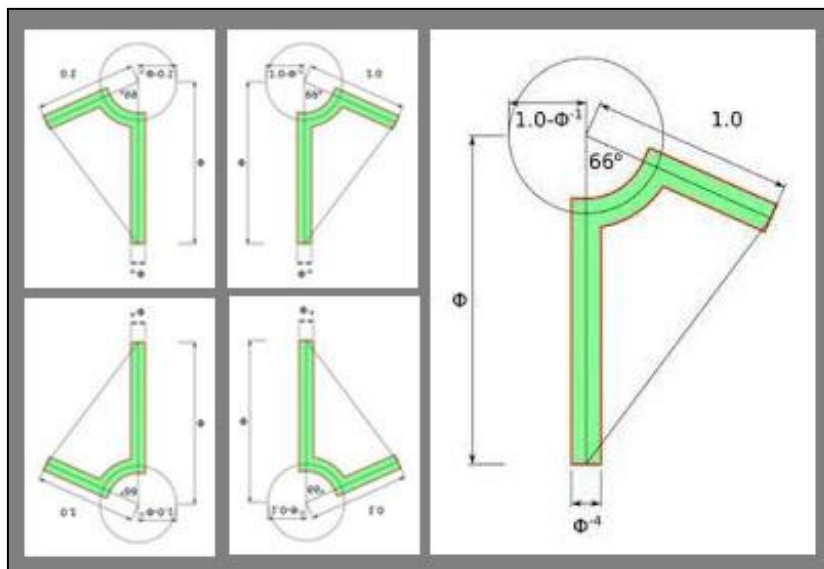

Figure No. (13) (An illustration of L66 shape that is converting detrimental energies, into beneficial energies) (<https://www.pinterest.com/pin/329466528988861999/>)



Figure No. (14) (Eman Osama – Confusion - Mixed media on wood -65 × 95cm – 2016) (the researcher) – (One of the contemporary Egyptian artists, born in Giza in 1976, has a clear imprint in the field of graphics and has won many local awards. Assistant Professor, Faculty of Fine Arts, Department of Graphic).

The shape helps to regulate the electric energy to balance the electromagnetic fields and to achieve coordination and balance in the interaction of these fields with the bio-energy structure in the body" (<https://sites.google.com/site/alinsanalmoutawezan/page2> 9-25-2020).

"The letter (L) is one form of dynamic engineering shapes that has a strong effect on the balance of bio-energy, which makes it possess a distinctive and great ability to protect the body from external damage and is used for people who were exposed to many electrical charges or received radiation or chemical treatment" (<http://biogeometry.com.eg/question.php#a2> 9-25-2020)

In the past, artists reached a great extent of charm and beauty in forming the letter (L) in paintings, creating a sensual, aesthetic and visual feeling, and nowadays, bio-geometric science has discovered that the letter (L), as a geometric shape, has supernatural powers in achieving the qualitative balance of bio-energy in the human body. Figure No. (14)&(15) are clear examples of the letter (L) shaped drawing. In the composition of the artwork, the artist used the shape of the letter (L), which is one of the most important and successful formations in the plastic arts. It is also considered one of the strongest effects in dispersing the excess bio-energy, left over from electrical devices as well as magnetic fields in the language of energy science, which makes it a distinctive and great ability to protect the human body from any external damage and is used for people, who were exposed to many electrical charges or received radiation, or chemical treatment. The artist also used the pencil lines technique,

which relied on tangled and intersecting lines that carry tremendous movements and energies emitted from those lines. The left illustration of the artwork expresses the movement of the energy direction emitted from the drawn lines of the artwork that form the letter(L).

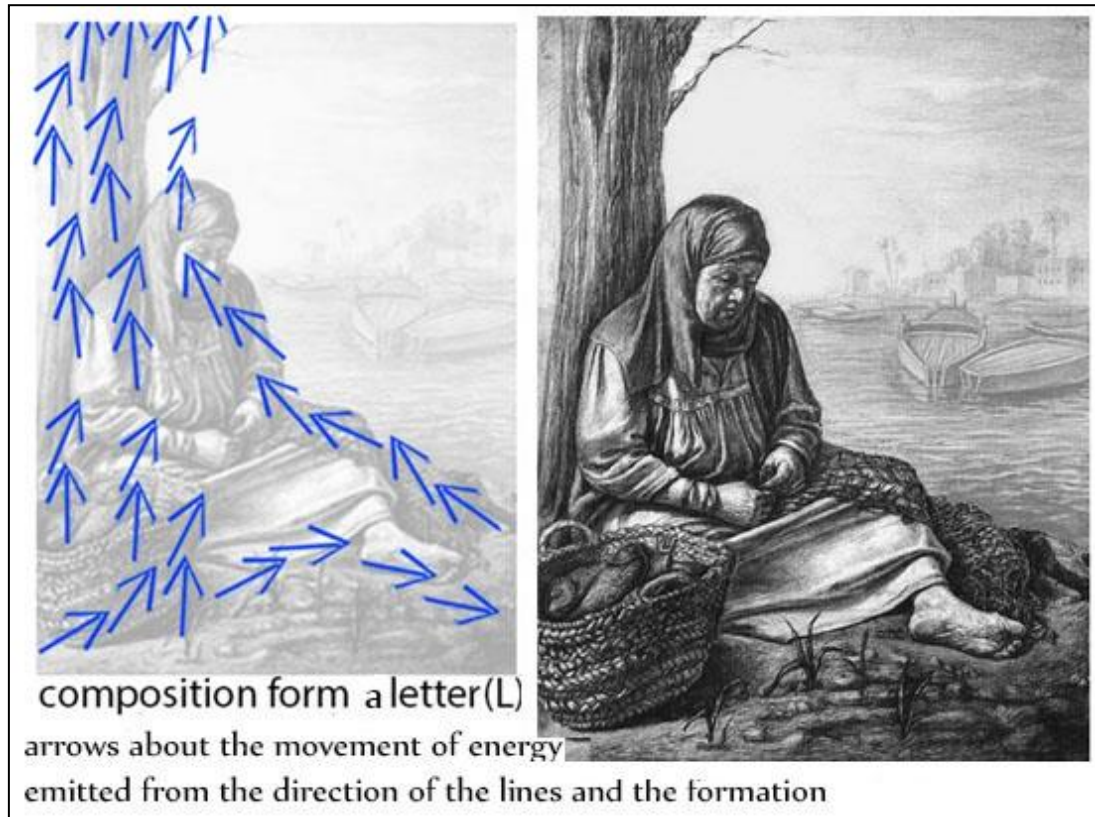

Figure No. (15) (the researcher - huntress - Drawing - Pencil on paper - 50 x 70 cm – 2001) (the researcher)

In the past, artists reached a great extent of charm and beauty in forming the letter (L) in paintings, creating a sensual, aesthetic, and visual feeling, and nowadays, bio-geometric science has discovered that the letter (L), as a geometric shape, has supernatural powers in achieving the qualitative balance of bio-energy in the human body. Figure No. (14)&(15) are clear examples of the letter (L) shaped drawing. In the composition of the artwork, the artist used the shape of the letter (L), which is one of the most important and successful formations in the plastic arts. It is also considered one of the strongest effects in dispersing the excess bio-energy, leftover from electrical devices as well as magnetic fields in the language of energy science, which makes it a distinctive and great ability to protect the human body from any external damage and is used for people, who were exposed to many electrical charges or received radiation, or chemical treatment. so when the artist uses the form (L) in the composition of his artwork through his lines which relied on tangled and intersecting lines, this will lead to tremendous movements and energies emitted from those lines. It helps in dispersing the negative and electromagnetic energy spread around the recipient, causing a kind of Serenity and psychological calm. One can deduce from this discussion of the formations of the artworks and their interconnectedness with the science of energy and the effect of the three most famous formations in artworks (the pyramid (A), the circular (O), and the letter (L) shapes), which have clear connotations in bio-geometry, also have a direct effect on the energy and balance of the human body, and as a consequence on his/her mood.

THE PSYCHOLOGY OF COLOR AND ITS EFFECT ON THE RECIPIENT:

"The word color denotes in its broad sense a lot of meanings, it includes, for example, that visual sense resulting from the difference in the lengths of light waves in the visible rays, which is the difference that results in the eye's sense of different colors, beginning "from red (which has the longest wavelength of the visible light rays) to the violet color", which has the shortest wavelength of these rays." (Abdul Fattah.Riyadh (1995) P. 315, 319. (Paraphrase), "Just as the origin of colors, as some people call it (being the color) that the one can see when a white ray passes through a glass prism, this white ray decomposes into a group of seven colors starting on the side with the violet rays, then the indigo, then the blue, then the green, then the yellow, then the orange, and then the red." (Abdul Fattah.Riyadh (1995) P. 315, 319. (Paraphrase)

These seven colors of the spectrum remind us of the colors of the seven energy centers in the human body, as shown in figure no. (9). One can see the color violet in the middle of the top of the head, it is the first energy centers in the human body and it is responsible for spirituality, and the indigo color is the color of the second energy centers in the human body responsible for thinking, communicating and socializing. As for the blue color, we can see it concentrated in the neck and shoulders, and it is considered the third energy center in the human body, then move to the green color responsible for the chest and the heart, which is considered the fourth energy center, then the yellow color responsible for the stomach is the fifth energy center in the human body, then, the color orange is the sixth energy center in the human body responsible for the colon and the feeling of hunger, and therefore the most successful restaurants are those who paint their walls orange to open the appetite, and the last energy center in the human body is the seventh place symbolizes the red color, which is the area of the bladder.

Perhaps we can deduce from this the similarity of the colors of the spectrum arrangement with the colors of the energy centers of the human body and how each color affects the area similar to its wavelength, the violet color is the color of meditation and spirituality, and it represents the highest peak in the head and the indigo color is the color of deep thinking and so on. The association of color vision with the treatment or effect of the Energy Center represented by the body means that each center of the bio-energy in the human body is affected by seeing that color, and it has been discovered that the vision of a certain color on regular basis allows this area to be treated and healed. As for the white, black, and gray shades, they are considered monochromatic, but if one goes deeper into the being of the white color, one sees it as a form of the seven colors of the spectrum, which includes all the characteristics of the seven colors, so the white color is a color full of energy and vitality because it combines the energies of all the seven colors. As for the black color, it can absorb all the energies of the colors, these are two opposite colors. when they are next to each other, they produce a group of vital energies that result from the color contrast and the movement of the lines, as well as spaces. When drawing on a white surface with a set of black lines intersecting and intertwined, it produces from those black lines the power of the line mentioned "At the beginning of the search" leaving white spaces that carry inside them all the energies of the seven colors of the spectrum, due to the importance of the color contrast between the two colors of the white and the black. As well as the conflict caused by the contrast of black and white spaces, horizontal, vertical and diagonal lines, thick and thin lines,

light, dark, sharp and curved lines. Wright (2008) defines it as the effects of the electromagnetic radiation of light on human mood and behavior—a universal psychophysical reaction, which is not as heavily influenced by culture, age, and gender as it is generally thought. It must be noted that there is a great difference between color psychology and color symbolism. The context of color can be understood to be color symbolism whereas the psychological properties of color are associated with moods of people in general, Wright (2008), which relates respectively, to the body, the mind, the emotions, and the essential balance between these three. The emotional effects of the basic colors are as follows; first Red as being with the longest wavelength, red is a powerfully strong, and very basic color. It has the property of appearing to be nearer than it is and therefore it grabs people's attention first. It may activate the "fight or flight instinct. Pure red is the simplest color, with no subtlety. It is stimulating and lively, very friendly, but at the same time, it can be perceived as demanding and aggressive, although the red colored spaces have courage, strength, warmth energy with basic survival instinct, "fight or flight," stimulation masculinity, with excitement effects on people (Wright, 1998), also defiance, aggression, visual impact, and strain are among the negative impacts of red color. According to Eiseman (2006 Yellow is thought of as joyful, outgoing, open, and psychologically friendly), yellow is the strongest color, in color-mood association studies, yellow is associated with comedy, a happy mood, and also with playfulness. Yellow ribbons have been used as a sign of hope and optimism since the nineteenth century (p. 45), psychologically yellow is the strongest color, it is about emotions, self-esteem, and creativity (Wright, 1998). Light pastel yellows are seen as childlike, canary yellow is delicate and feather-soft. Blue encourages intellectual activity, reason, and logical thought. It is the color of intellect, there are some evidences about raising blood pressure with the color red, while blue is deemed to lower the blood pressure. Certainly, it is a soothing, calming color encouraging reflection, it is in nature, the sky and the sea, Wright, 1998, p. 27). Strong blues stimulate clear thought while lighter and soft blues calm the mind and aid concentration. How Color Psychology Works? When light strikes any colored object, the object absorbs only the wavelengths that exactly match its atomic structure and reflects the rest of the colors. When light strikes the human eye, the wavelengths do so in different ways influencing our perceptions. The hypothalamus is the part of the brain governing our hormones and our endocrine system when light hits the retina it is converted to electrical impulses that are then transmitted to the hypothalamus for interpretation. The hypothalamus houses the body's biological clock (Wright, 2008). This is so because it governs our body's temperature, our appetite, sexual functions, sleeping, and behavioral patterns, and so on. It has been proved several times that color has a physical effect on humans due to its energy; an experiment that was carried out on blind people to identify some colors, the experiment has resulted in that these blind subjects have been identifying the colors with no problems at all. (Sevinc Kurt1 and Kelechi Kingsley Osueke2, 2014)



Figure No. (16) (illustration to identify the seven energies and their colors of the human body)

<https://www.alrakia.com/100098-100098/>

https://twitter.com/soul369_/status/1278776875922460672/photo/3

COLOR AS A THERAPEUTIC TOOL:

The 'Color' is known to have an intense effect on our mood, behavior, action, metabolism, and hence on overall health. The therapeutic role of color can be briefed as follow: Lack of natural daylight impairs our mood. Exposure to artificial lights during the day is effective for mood. The full-spectrum fluorescent lamps with a bright light that matched the white sunlight of the day, bring relief to various glandular disorders, insomnia, fatigue, and mental ailments (Nisreen Hussain, Deepak Kumar, Touseef Hussain Trak, 2018).

The more the one gets exposed to various colors of nature, the more he/she enjoys its beauty and receives energized vibrations from various hues. The impact is positive and gives relief from pain, depression, anxiety, etc. making the mind more cheerful and the body gets healthier. The healing through colors is a high vibration healing with just energy, i.e., 'Color'. Colors maintain the balance between the physical, emotional, mental, and spiritual states of human beings thereby leading to the cure of disorders and diseases. (Nisreen Hussain, Deepak Kumar, Touseef Hussain Trak, 2018).

Art therapy was originally developed as a technique for treating mental illness, psychological trauma, and other mental problems, and was first used in the fields of psychiatry, psychology, and clinical psychology. In Japan, art therapy has used materials from a variety of fields, including painting, music, and classical Japanese poetry. According to Tokuda, although each of these techniques has its theory and methodology, what they all have in common is that there is a process of art creation, and this art is then used to go beyond ordinary expository language to make it possible for individuals to directly express their current circumstances or mental state (Tokuda, 2011, pp.2-21) (Paraphrase). In this way, art therapy is typically conducted, by using artworks created in a variety of situations, to determine patients' mental

status and analyze their condition, understand their current status, and prescribe the appropriate treatment (Iimori, Nakamura, et al.,2011, pp.36-198) (Paraphrase).

In a nationwide survey of art therapists conducted in 2012 in Japan, the results showed that nearly the same number of therapists who performed treatments on “people with no particular problems” as “people suffering from mental illnesses.” Also, more therapists responded that “change of mood / stress relief” and similar effects could be expected from treatment than things like “improvement of symptoms,” and “problem resolution” (Kawata, Nishi, et al. 2012, p.9). (Paraphrase) New forms of art therapy with the objectives of “staring into one's subconscious” and “self-healing” are being developed which individuals can perform on their own without the mediation of a specialist in art therapy (Yoshida, 2009 and 2005). In this way, art therapy is transforming from a technique for treating mental illness to a source of recreation, and is now being used as a means of achieving a variety of goals such as improvement of self-development and self-awareness (Keer, Linkoping, 2014.) (Paraphrase). Based on the aforementioned, one can say that this harmony that a person feels when watching a painted artwork, in which a successful composition is achieved and the effects of lines, and colors are nothing but vibrations of bio-energy that spreads in the place, where it has created an invisible, but tangible metaphysical space that cannot be seen with the naked eye, but the one can feel it, when our mood and psychological state change and a qualitative balance is created, it is translated into "positive energies" in the language of bio-energy.

RESULTS' DISCUSSION:

- 1- From the research, it can be concluded that there is a relationship between bio-geometry and arts types, especially the art of drawing, based on the lines and the contrast between the black and the white.
- 2- The art of drawing, through composition, lines, and colors, can affect the space about the recipient, the improvement, the dispersion, or even the balance of bio-energy.
- 3- The recipient's body energies will imitate the energies emanating from the artworks, and energy of the recipient will be moving like the energy movement of artwork lines, and they come out from the body of the recipient and head upwards, then vanish in the space, creating some sort of psychological balance, and improving the recipient's mood.

RECOMMENDATIONS:

- 1-The researcher underlines the necessity of conducting more studies that show the importance of bio-energy for Man and its effect on the visual arts.
- 2- The necessity of giving training and knowledge courses about bio-energy sciences for artists and students to facilitate their application means and make use of them in the fields of treatment and alternative medicine through the art of drawing.

REFERENCES:**A.- BOOKS:**

- 1- Eiseman, Leatrice. Color: Messages and meanings: A Pantone color resource. Cincinnati, Ohio: Gloucester, MA: Hand Books Press distributed by North Light Books. (2006).
- 2- El birulosity, Lobna Abd El aziz Ahmed. Ranyin El aitizan fi El emara wa El omran, Cairo Master's, Faculty of Engineering, Department of Architectural Engineering, Cairo University, (2006).
- 3- Imori, M., Nakamura, K., et al., Art Therapy. Tokyo, Japan: Nihon Hyoronsha, (2011), Chapter 3-12, (pp.36-198).
- 4- Tokuda, Y., In Imori, M (Ed.),: Art Therapy. Tokyo, Japan: Nihon Hyoronsha, (2011), Chapter 1, (pp.2-21).
- 5- Riad, Abd El fatah. El takwin fi Alfunun Altashkilia. Egypt: Dar El nahda El arabia, (El tabaa 5), (1995).
- 6- Sulayman, Hassan. Saykulujiat El khotot. kayfa taqraa sora. Cairo: Dar El kitab El arabia liltebaa, (1967).
- 7- Wright, A., Color Affects: Beginner's guide to color psychology. London, England, (1998).
- 8- Yoshida, E. はじめてのアートセラピー [The First Art Therapy], Tokyo, Japan: Kawade Shobo Shinsha Publishers, (2005).
- 9- Yoshida, E. アートセラピーで知るこころのかたち [Understanding Mental State through Art Therapy]. Tokyo, Japan: Kawade Shobo Shinsha Publishers, (2009).

B. - WEBPAGE:

- 1- <http://alwafd.org/%D8%A3%D8%B3%D8%B1%D8%A9/264826-%D8%AA%D8%AE%D9%84%D8%B5-%D9%85%D9%86-%D8%A7%D9%84%D8%B7%D8%A7%D9%82%D8%A9-%D8%A7%D9%84%D8%B3%D9%84%D8%A8%D9%8A%D8%A9-%D8%A8%D9%85%D9%86%D8%B2%D9%84%D9%83-%D9%88%D8%AD%D9%88%D9%84%D9%87%D8%A7-%D9%84%D8%A5%D9%8A%D8%AC%D8%A7%D8%A8%D9%8A%D8%A> (20-11-2020)
- 2- <http://biogeometry.com.eg/question.php#a> (2-1-2021)
- 3- <https://sotor.com/%D8%B7%D8%B1%D9%82-%D8%A7%D9%84%D8%B9%D9%84%D8%A7%D8%AC-%D8%A8%D8%A7%D9%84%D8%B7%D8%A7%D9%82%D8%A9-%D8%A7%D9%84%D8%AD%D9%8A%D9%88%D9%8A%D8%A9> (2-1-2021)
- 4- <https://www.ahewar.org/debat/show.art.asp?aid=125039> (12-12-2020)
- 5- <https://sites.google.com/site/alinsanalmoutawezan/page2> (2-1-2021)
- 6- <https://journals.sagepub.com/doi/10.1177/2158244014525423> (11-11-2020)
- 7- https://www.academia.edu/590819/Colour_psychology_and_colour_therapy_Caveat_emptor_in_Color_Research_and_Application_36_3_pp229_234_2011 (12-10-2020)
- 8- <https://ep.liu.se/ecp/100/107/ecp14100107.pdf>. (11-11-2020)
- 9- https://www.researchgate.net/publication/330982270_HEALING_AND_THERAPY_WITH_COLORS (20-1-2021)
- 10- <http://www.colour-affects.co.uk/how-it-works>. (11-1-2021)
- 11- <https://www.hollysteflik.com/biogeometry> (12-12-2020)

12- <https://www.pinterest.com/pin/329466528988861999/> (11-1-2021)

C. - JOURNAL OR SERIAL PAPER FROM THE INTERNET:

- 1- Aba Al-Khel, Ibrahim Abdullah. "Baramatiyah architecture - Za Hadid and Patrick Schumacher architecture", construction, (2017),
<https://albenaamag.com/2017/10/07/%D8%B9%D9%85%D8%A7%D8%B1%D8%A9-%D9%85%D8%AD%D8%B7%D8%A7%D8%AA-%D8%A7%D9%84%D8%B3%D9%83%D9%83-%D8%A7%D9%84%D8%AD%D8%AF%D9%8A%D8%AF%D9%8A%D8%A9/> (3-11-2020)
- 2- Abd El azeem, motaz belah Gamal El din., Al asawiy, Mohamad Abd El fatah. "nahw dalil aistirshadiun mustahdath lasis wamaeayir tasmim almabani alsakania alty taeish fiha wahadat sakania mutakamilat alttaqat limuqawamat talbis alkahrumughnatisi, tasmim almabani alsakania almoasira", Cairo University Conference (2019)
- 3- Gin, Jerry., "THE SCIENCE OF BIOGEOMETRY", Cosmos and History: The Journal of Natural and Social Philosophy, vol. 11, no. 2, (2015)
<https://www.cosmosandhistory.org/index.php/journal/article/viewFile/505/838> (11-10- 2020)
- 4- Hussain, Nisreen. Kumar, Deepak. & Trak, Touseef Hussain., "Healing and therapy with colors" Indian Journal of Scientific Research 9(1):31-32, (2018)
https://www.researchgate.net/publication/330982270_HEALING_AND_THERAPY_WITH_COLORS (12-12- 2020)
- 5- Kawata, T., Nishi, K., et al. "Modern Art Therapy's Current State and Issues through Questionnaires and Interviews", Ministry of Education, Culture, Sports, Science and Technology Support Foundation for Strategic Research at Private Universities: 2012 Report, 1-42. https://www.keer.org/keer2014/papers/KEER2014_6.pdf (20-12-2020)
- 6- Kurt, Sevinc. and Osueke, Kelechi Kingsley. "The Effects of Color on the Moods, of College Students", Sage open, 2014,
<https://journals.sagepub.com/doi/10.1177/2158244014525423> .,(20-12-2020)
- 7- Linkoping, Keer. "Study on Color Art Therapy Techniques An examination of techniques which allow elderly patients with severe dementia and motor impairment of the hands to express themselves to the same extent as healthy people", "International conference on kansel engineering and emotion research", 2014, <https://ep.liu.se/ecp/100/107/ecp14100107.pdf>. (2-1-2021)
- 8- O'Connor, Zena. "Colour Psychology and Colour Therapy, Color forum," 2011,
https://www.academia.edu/590819/Colour_psychology_and_colour_therapy_Caveat_emptor_in_Color_Research_and_Application_36_3_pp229_234_2011. p. (36), 229–234,(22-12-2020)
https://ep.liu.se/en/conference-article.aspx?series=ecp&issue=100&Article_No=107 (4-2-2021)
- 9- Wright, A. "How it works". (2008) <http://www.colour-affects.co.uk/how-it-works> (2-1-2021)