

Improve the perception of the curriculum by using of three dimensional printing

Dr. Mona Mahmoud Mahmoud Ali

**Instructor- department of Printing, Publishing and Packaging design
Faculty of Applied Arts- Helwan University**

monamahmoud1981@gmail.com

Dr. Sherif Mahmoud Abd ELSAMEE

Instructor- department of Industrial - Faculty of Applied Arts- Helwan University

Introduction

With the technological development and quick Technical of the printing industry, a new printing technique has emerged, known as 3D Printing, a revolutionary technology that opens the a new industrial revolution. After the manufacture of tools and simple machines required special skill that only a few people have, there are machines that perform certain tasks to make certain objects more efficiently and quickly and on time.

With three-dimensional printing, it is impossible to print objects of any complex shape, once you have designed the object you want to print on AutoCAD or any similar program, and then the printer converts it to the desired product.

We are now in the process of using three-dimensional printing and adapting it in complex mechanical learning methods to make it easier for students to understand and study different mechanisms.

Keywords:

3D Printing - additive manufacturing - Complexity - Environmental Friendly.

Research problem:-

Failure to recognize and understand the students of some mechanical models while explained by traditional means.

Search Goal ;:-

Opening a new field in the methods of producing educational models, which allows accurate understanding of the mechanical models and thus provides opportunities for creativity and innovation among students.

Research importance:-

The research emphasizes the need to integrate three-dimensional printing applications into educational curricula and to benefit from them in developing teaching methods to simplify complex mechanical science.

Force search: -

If the use of printing three-dimensional to produce educational models will lead in turn to improve the level of education and the capabilities of students and provides opportunities to invest inventive inventory to the student - because the three-dimensional printing allows the student to transform his ideas to a tangible intellectual output can be implemented and tested and so can be applied.

Search limits :-

Temporal Limits: The limits allowed to complete research requirements.

Spatial limits: Special bodies to teach the theory of machines to complete the requirements of research.

Research Methodology:-

Proceed to the experimental approach to achieve the desired goal of the research.

Search terms: -

3D Printing manufacturing - Additive manufacturing

Research axes: -

The first axis: - includes the theoretical study to demonstrate the importance of three-dimensional printing and the extent of its use in mechanical teaching methods.

The second axis: - includes the applied study of the work model of mechanical mechanism and measure the extent of understanding and understanding of students to explain this method.

Summary of Applied Study

To complete the research requirements we will produce one of the mechanical models using three-dimensional printing, then follow the production process explain the lesson in the traditional way- explain the same lesson using the model using three-dimensional printing, and then measure the impact of understanding using both methods in the explanation.

The choice is made on a mechanical model **gear and drop** and used as part of the mechanical parts of some machines.

The design of the model was studied using the AutoCAD program and design it first 2D as shown in Figure 1, and then sketched it on the Sketch Up program, a program for drawing 3D models to start production and printing, a program that is easy for non-professional to use, simple Figure2.

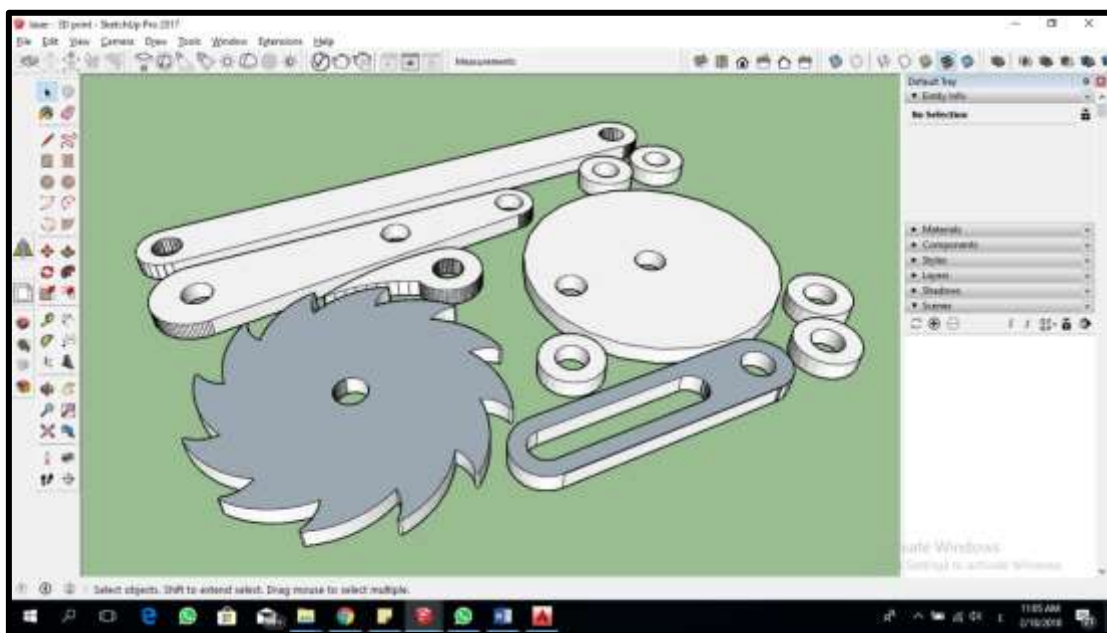
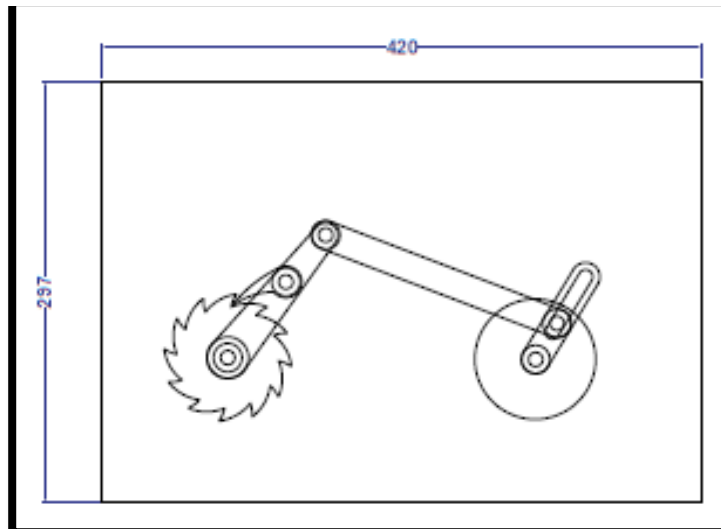

Figure 1



• Measuring the effect of understanding using both methods in the explanation

The questionnaire was designed in the light of the research problem and its hypotheses. The form consisted of three tables. Table 1: Measuring the comprehension of understanding by conventional methods of explanation, Table 2: Measuring the comprehension of understanding by product model by printing three dimensions. Table 3: Measuring the application of three-dimensional printing systems (sender).

The questionnaire was displayed to the students who Studied the principles of machine theory after explanation in the traditional way and with using the model produced by the three-dimensional printing. The number of the sample community is 100 recipients - the questionnaire questions were also presented to the sender and measured their satisfaction.

After the questionnaire was ending, a statistical analysis of the results of this questionnaire was conducted at the Center for Statistical and Statistical Studies at the University of Cairo.

Results:-

- 1 - There is a lack of understanding of recipients of some mechanical models while explained by traditional means.
- 2 - Application of the use of three - dimensional printing and product model to explain one of the complex lessons - will lead to easy understanding of the lesson for the recipient and creates an educational environment built on understanding and consolidation of knowledge.
- 3 - Use educational models reduce the individual differences that may appear from the explanation in traditional ways.

Recommendations:-

- 1 - The concept of using three-dimensional printing must be established to make educational models used in the educational process to open a new field in the methods of producing educational models, which allows to create an integrated educational environment more exciting and exciting and full of effective discussion between the recipient and the explanatory, and it has achieved the ability to Creativity and innovation among some recipients.

References: -

Scientific messages:-

1 - Youssef - Ghada Atta - Evolution of three - dimensional printing (with the application on digital maps produced in Egypt) - Dissertation unpublished.

2 - Mahmoud - Nevin Abdel Aziz - Methodology design and production of the book of science in the elementary school education in the Egyptian government schools - a doctorate unpublished letter - 2004.

3 - Ibrahim - Wessam Unsi - Preparation of a scientific basis for the construction and evaluation of the first model to achieve the requirements of design and production in advanced mineral products - unpublished Ph.D.

4 - Banna - Rasha Mahmoud Ahmed - interactive between traditional education and electronic publishing education to measure the efficiency of mixed education - a doctorate unpublished - 2012.

Arabic Books: -

5- Khalaf Allah - Muhammad Jaber - The Concept of Educational Means and Their Types - Dar Al Fajr for Distribution and Publishing (2006)

6 - Mawafi - Amin - theories of modern communication - Dar Fajr for distribution and publishing 2015.